

ER2 Dual Speed inverter

With Hook Suspension

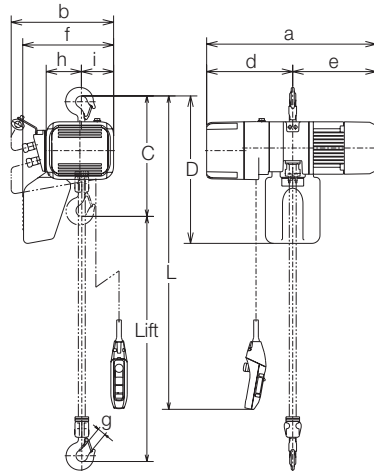

- Five meters of power supply cable as standard accompanies.
- Optional length of lift, push button cord and power supply cable besides standard is available on your request.
- Extending the load chain is prohibited with additional links.
- Steel chain containers are available as option as shown in Section of "Chain Containers" if your lift is more than capacity of the standard container volume.

Specifications

Capacity (t)	Product Code	Hoist Body	Standard Lift (m)	Push Button Cord L (m)	Lifting Motor		Lifting Speed (m/min)*			Load Chain		Classification ISO/FEM/ASME	Test Load (t)	Net Weight (kg)	Additional Weight per 1m Lift (kg)						
					Output (kW)	Rating (%ED)	50/60Hz		Diameter (mm)	Chain Falls											
							High	Low													
125kg	ER2-001IH	B			0.56		Preset	16.6	2.8	4.3	x 1		156kg	27	0.42						
							Adjustable		1.4												
	250kg						ER2-003IS										0.9		Preset	10.8	1.8
																			Adjustable		0.9
500kg	ER2-003IH	C			0.56		Preset	15.7	2.6	6	x 1	M5/2m/H4	625kg	32	0.81						
							Adjustable		1.3												
	ER2-005IL															0.9		Preset	4.5	0.8	
																		Adjustable		0.4	
1	ER2-005IS	D	3	2.5	40/20		Preset	8.5	1.4	7.7	x 1		1.25	45	1.33						
							Adjustable		0.7												
	ER2-010IL																	Preset	4.2	0.7	
																		Adjustable		0.3	
1.5	ER2-010IS	E			1.8		Preset	8.2	1.4	10.2	x 1		2.5	73	2.3						
							Adjustable		0.7												
	ER2-015IS																	Preset	5.3	0.9	
																		Adjustable		0.4	
2	ER2-020IL	F			3.5		Preset	4.3	0.7	11.2	x 1	M4/1Am/H4	3.13	100	2.8						
							Adjustable		0.4												
	ER2-020IS																	Preset	8.2	1.4	
																		Adjustable		0.7	
2.5	ER2-025IS	E			2.8		Preset	6.6	1.1	10.2	x 2		3.75	105	4.7						
							Adjustable		0.6												
	ER2-030IS																	Preset	5.2	0.9	
																		Adjustable		0.4	
5	ER2-050IS	F					Preset	3.3	0.6	11.2	x 2		6.25	128	5.6						
							Adjustable		0.3												

Note: The high speed is preset to the maximum speed in KITO factory. The speeds are adjustable between High and Low.

Dimensions (mm)

Capacity (t)	Product Code	Headroom C	D	a	b	d	e	f	g	h	i
125kg	ER2-001IH	350	430	535	345	276	259	284	27	99	117
250kg	ER2-003IS										
	ER2-003IH		568		348		268		283	27	113
500kg	ER2-005IL	370	490	571	348	300	271	283	27	113	106
	ER2-005IS			568							
1	ER2-010IL	430	550	614	376	316	298	335	31	129	118
	ER2-010IS			623							
1.5	ER2-015IS	510		710		372	338		34		
2	ER2-020IL	575	630		427		356	384.5	39	160.5	137.5
	ER2-020IS	590		767		411					
2.5	ER2-025IS	625	840	800	445	401	399	437.5		173.5	142.5
3	ER2-030IS	785	920	767	427	411	356	397	44	216	82
5	ER2-050IS	850		800	445	401	399	439	47	231.5	84.5