

ER2SP Dual Speed inverter

With Plain Trolley

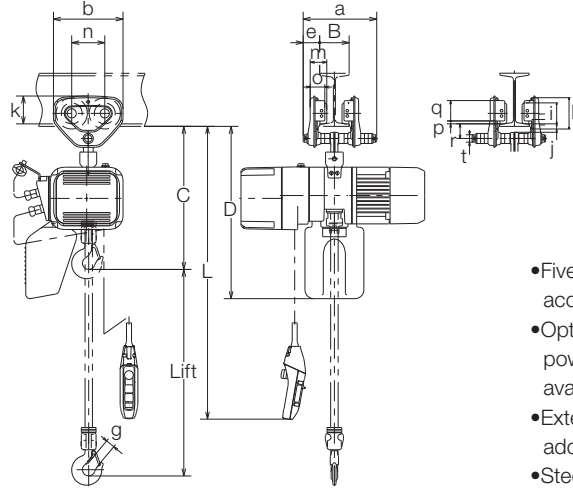

- Five meters of power supply cable as standard accompanies.
- Optional length of lift, push button cord and power supply cable besides standard is available on your request.
- Extending the load chain is prohibited with additional links.
- Steel chain containers are available as option as shown in Section of "Chain Containers" if your lift is more than capacity of the standard container volume.
- The hoist direction to a beam for 3 t or 5 t is different 90 degrees.

Specifications

Capacity (t)	Product Code	ER2										TSP			Test Load (t)	Net Weight (kg)	Additional Weight per 1m Lift (kg)	
		Hoist Body	Standard Lift (m)	Push Button Cord L (m)	Lifting Motor		Lifting Speed (m/min)*		Load Chain	Classification ISO/FEM /ASME	Flange Width B (mm)			Min. Radius Curve (mm)				
					Output (kW)	Rating (%ED)	50/60Hz				Diameter (mm) x Chain Falls	Standard	Option					
							High	Low					W20 (203mm)					W30 (305mm)
125kg	ER2SP001IH	B			0.56		Preset	16.6	2.8	4.3 x 1								
	ER2SP003IS						Adjustable	1.4	1.8									
250kg	ER2SP003IH	C			0.9		Preset	10.8	1.8	6 x 1	M5/2m /H4	50 to 102	103 to 203	1100				
	ER2SP005IL						Adjustable	0.9	2.6									
500kg	ER2SP005IS	D	3	2.5	0.56	40/20	Preset	15.7	2.6	7.7 x 1		82 to 153	154 to 305					
	ER2SP010IS						Adjustable	1.3	1.3									
1	ER2SP010IL	E			0.9		Preset	4.5	0.8	10.2 x 1								
	ER2SP015IS						Adjustable	1.4	0.7									
1.5	ER2SP020IL	F			1.8		Preset	8.5	1.4	11.2 x 1	M4/1Am /H4	100 to 178	179 to 305	2300				
	ER2SP020IS						Adjustable	0.7	0.7									
2	ER2SP025IS	G			3.5		Preset	4.2	0.7	10.2 x 2								
	ER2SP030IS						Adjustable	0.3	0.3									
2.5	ER2SP030IS	H			2.8		Preset	8.2	1.4	11.2 x 2								
	ER2SP050IS						Adjustable	0.7	0.7									
3	ER2SP050IS	I					Preset	5.3	0.9									
5	ER2SP050IS	J					Adjustable	0.4	0.4									

Note: The high speed is preset to the maximum speed in KITO factory. The speeds are adjustable between High and Low.

Dimensions (mm)

Capacity (t)	Product Code	Headroom C	D	a	b	e	g	h	i	j	k	m	n	o	p	q	r	t
125kg	ER2SP001IH	395	470															
250kg	ER2SP003IS																	
250kg	ER2SP003IH			204	182	46	27	82	60	21	76	47.5	84	42		54	38	22
500kg	ER2SP005IL	415	530															
	ER2SP005IS																	
1	ER2SP010IL	470	590	249	236	56	31	106	71	28	95	56	112	50	10	69	50	25
	ER2SP010IS																	
1.5	ER2SP015IS	570					34											
2	ER2SP020IL	635	690	300	280	69		127	85	34	112	71	131	63		83	62	32
	ER2SP020IS			650				39										
2.5	ER2SP025IS	680	890	320	324	79		148	100	36	134	80	152	74		102	68	36
3	ER2SP030IS	780					44											
5	ER2SP050IS	840	910	297	400	53	47	169	118	46	144	81	178	70		104	88	54